

**MANUAL DE MONTAGEM  
ASSEMBLY INSTRUCTIONS  
INSTRUCCIONES DE MONTAJE**

**COD BR: BC 75**



# Sumário Summary Resumen

Introdução Introduction Introducción	.....	3
Antes de começar Before starting Antes de comenzar	.....	4
Evite acidentes Avoid accidents Evitar accidentes	.....	4
Dimensões e ferramentas Dimensions and tools Dimensiones y herramientas	.....	5
Identificação das peças Identifying parts Identificación de las piezas	.....	6
Acessórios incluídos na caixa Hardware included in box Accesorios incluidos en la caja	.....	7
Montagem do móvel Furniture assembly Montaje del mueble	.....	8

## Introdução Introduction Introducción

Leia atentamente este manual e siga os passos indicados para que o produto não perca a garantia e também para uma perfeita montagem.

Read this manual and follow the steps in order to keep the guarantee and also for the perfect fit.

Lea este manual y siga los pasos para que el producto no pierda la garantía y también para el ajuste perfecto.

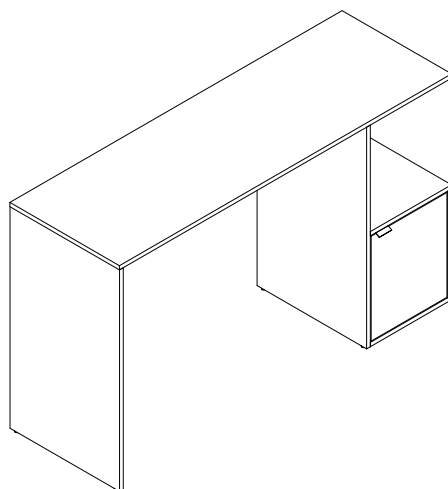

## Antes de começar Before starting Antes de comenzar

Antes de começar a montagem prepare o ambiente, deixando-o completamente limpo e com bom espaço para iniciar o trabalho.

Prepare the room before starting the assembly, leaving it completely clean and the area in good condition to start the work.

Antes de comenzar el montaje preparar el ambiente, dejándolo completamente limpio y con bueno espacio para comenzar el trabajo.

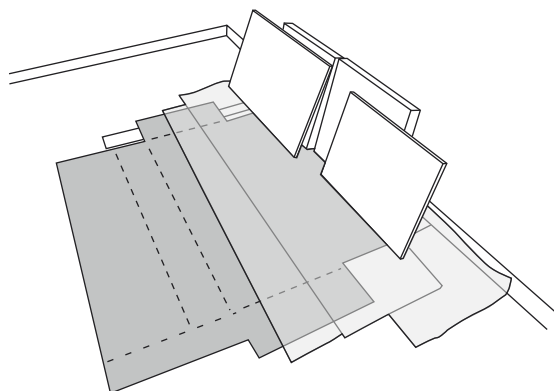

Utilize o papelão da própria embalagem para separar e apoiar as peças retiradas das caixas.

Use the cardboard of the packaging to separate and support the parts removed from the boxes.

Utilice el cartón de la embalaje para separar y apoyar las piezas desmontadas de las cajas.



Forre a área de montagem com um cobertor ou tapete. Assim, você evita avarias nas peças durante o processo de montagem.

Cover the assembly area with a blanket or carpet to avoid damaging the parts during the assembly process.

Cubrir la zona de ensamble con una manta o alfombra. De este modo, se evitan daños en las piezas durante el proceso de montaje.



## Evite acidentes Avoid accidents Prevenir accidentes

Solicitamos observar atentamente as orientações de montagem como: fixação do produto na parede, colocação de cola em locais específicos necessários, o peso suportado pelo produto, etc...

We request you to carefully observe the assembly instructions as: fixing the product on the wall, adding glue in needed and specific places, product weight limit, etc.

Pedimos que lea atentamente las instrucciones, principalmente las informaciones de fijación del producto en la pared, colocación de pegamento en local específico y necesario, el peso soportado por el producto etc...

Não escale ou se apoie no móvel.

Do not climb or lean on the furniture.

No se suba ni se apoye en el mueble.

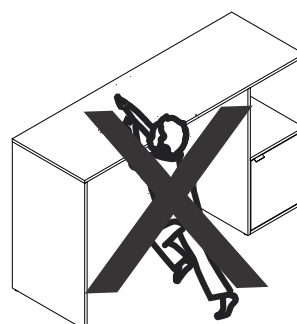

Dimensões e ferramentas  
Dimensions and tools  
Dimensiones y herramientas

Dimensões:

L: 1350 A: 800 P: 445 mm

Dimensions:

W: 53.14 H: 31.49 D: 17.51 inches

Dimensiones:

L: 1350 A: 800 P: 445 mm

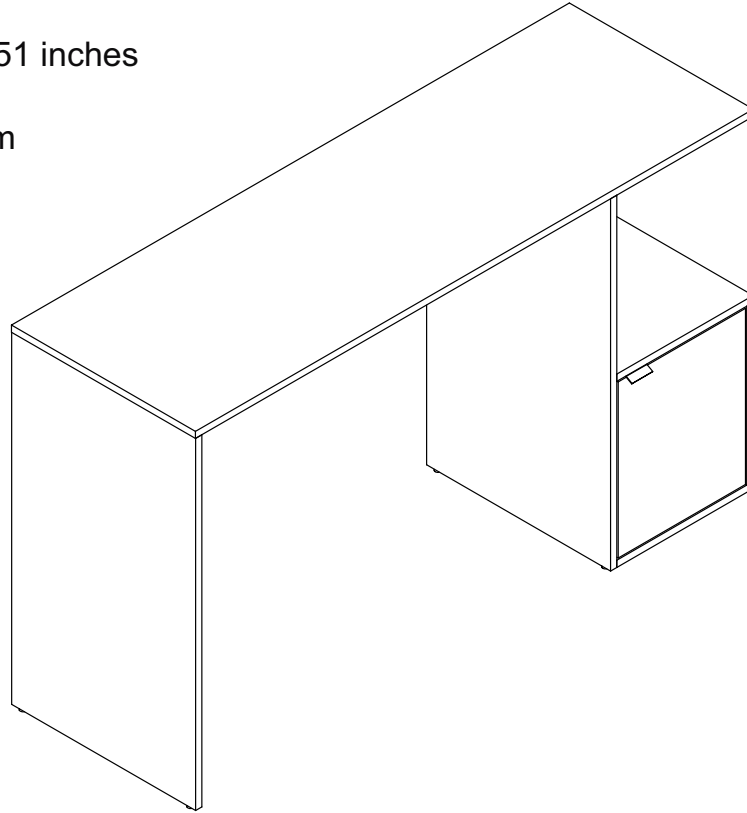

Limpeza  
Cleanig  
Limpieza



Pano levemente umedecido com água, seguido de pano seco, não utilizar produtos químico ou abrasivos.  
Slightly dampened cloth and after a dry cloth, do not use chemicals or abrasives.  
Solamente utilizar un paño húmedo y después un paño seco, no utilice productos químicos o abrasivos.

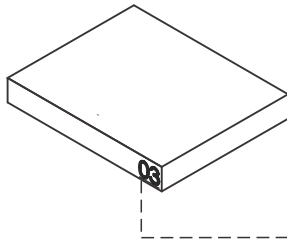

**UTILIZE ALCOOL APENAS PARA REMOVER O NUMERO DAS PEÇAS**  
**USE ALCOHOL ONLY TO REMOVE PART NUMBERS**  
**UTILICE ALCOHOL SOLAMENTE PARA ELIMINAR EL NUMERO DE LAS PIEZAS**

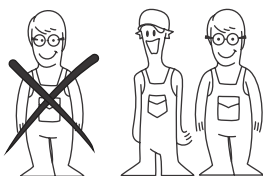

Para facilitar a montagem, utilize uma parafusadeira elétrica.  
To improve assembly, use an eletronic screwdriver.  
Para facilitar el armado, utilice un destornillador eléctrico.

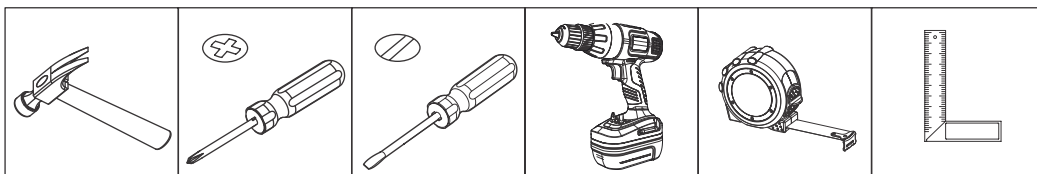

# COD BR: BC 75

PEÇA	DESCRIÇÃO	QUANT.	PART	DESCRIPTION	QTY	PIEZA	DESCRIPCIÓN	CANTIDAD
001	TAMPO	1	001	TOP	1	001	TAPA	1
002	LATERAL ESQUERDA	1	002	LEFT SIDE	1	002	LATERAL IZQUIERDA	1
003	DIVISÓRIA	1	003	PARTITION	1	003	PARTICIÓN	1
004	LATERAL DIREITA	1	004	RIGHT SIDE	1	004	LATERAL IZQUIERDA	1
005	BASE	1	005	BASE	1	005	BASE	1
006	PRATELEIRA	1	006	SHELF	1	006	REPISA	1
007	COSTA MAIOR 15 mm	1	007	LONGER BACK 0,59 in	1	007	REVÉS MAYOR 15mm	1
008	COSTA MENOR 15 mm	1	008	LOWER BACK 0,59 in	1	008	REVÉS MENOR 15mm	1
010	PORTA	1	010	DOOR	1	010	PUERTA	1
011	COSTA	1	011	BACK	1	011	REVÉS	1

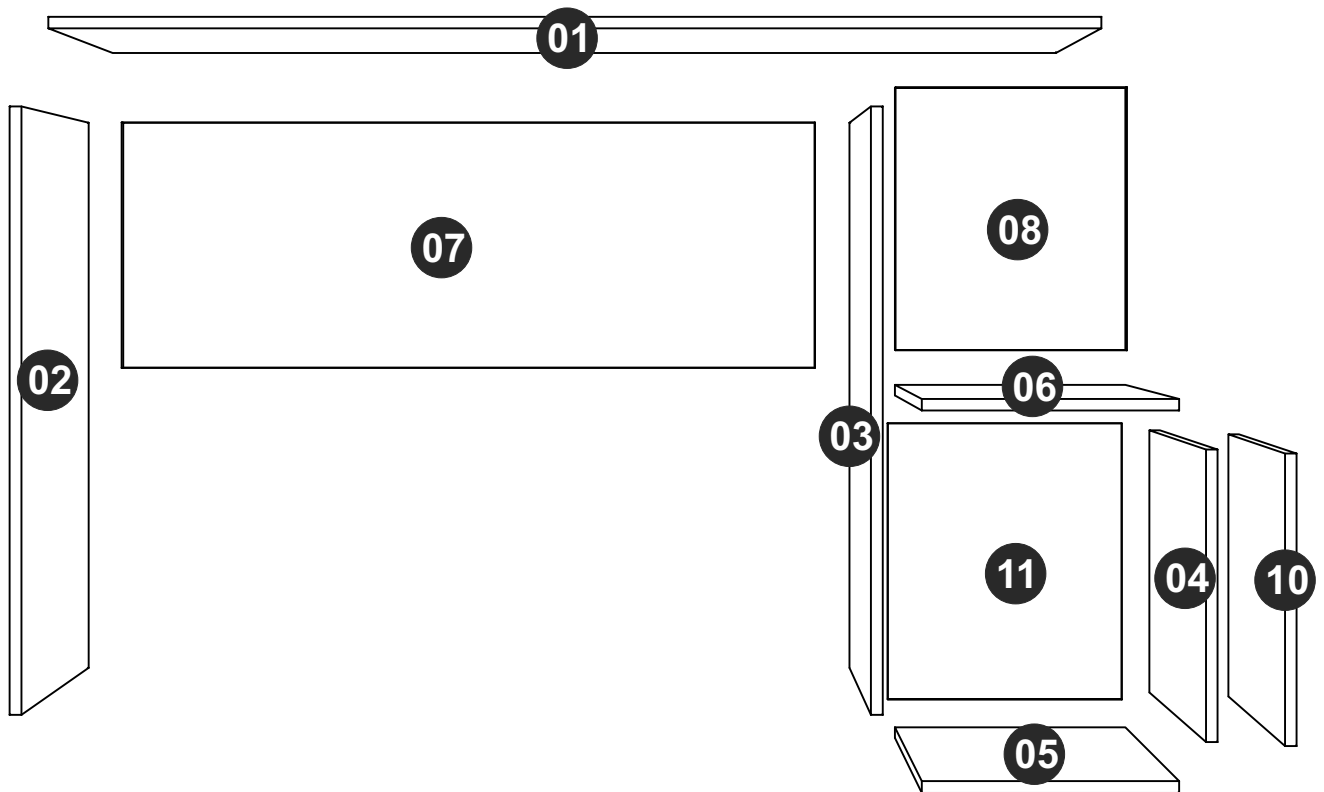



TAPA FUROS x 16  
STICKER x 16  
TAPAS PLÁSTICAS x 16

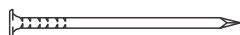

EF 000168 X 20  
10X10 C/C



EF 000106 x 10  
3,5X14 CC



EF 000033x 20  
8x30



GIZ x 01  
CHALK x 01  
TIZA x 01



EF 000216 X 16



EF 000094 X 16



PÉS REDONDOS x 6  
ROUND FEET x 6  
PIES REDONDOS x 6



EF 000025 X 2

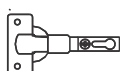

EF 000043 X 2

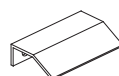

PUXADOR x 1  
HANDLE x 1  
MANIJA x 1



SUPORTE PLÁSTICO x 1  
pLASTIC SUPPORT x 1  
SOPORTE PLASTICO x 1



EF 000132 x 2  
4X50 CC

Utilize para medir as ferragens.

Utilice para medir el herraje.

Use for measuring the hardware.

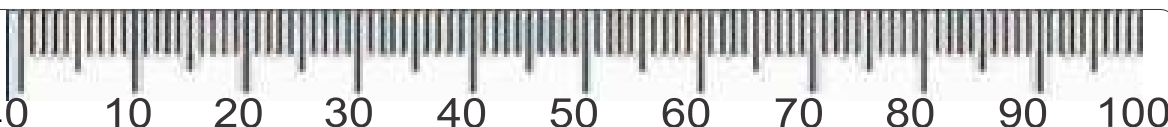

**Garantia (exclusivo para o Brasil/exclusivo de Brasil/exclusive to Brazil):**

A garantia dos produtos fabricados pela BRV Móveis, abrange eventuais defeitos-vícios de fabricação, no prazo estabelecido pelo código de Defesa do Consumidor, em seu artigo 26.II. o qual prevê a garantia de 90 (noventa) dias.

**A** = 18KG - 39.68LB

**B** = 5KG - 11.02LB

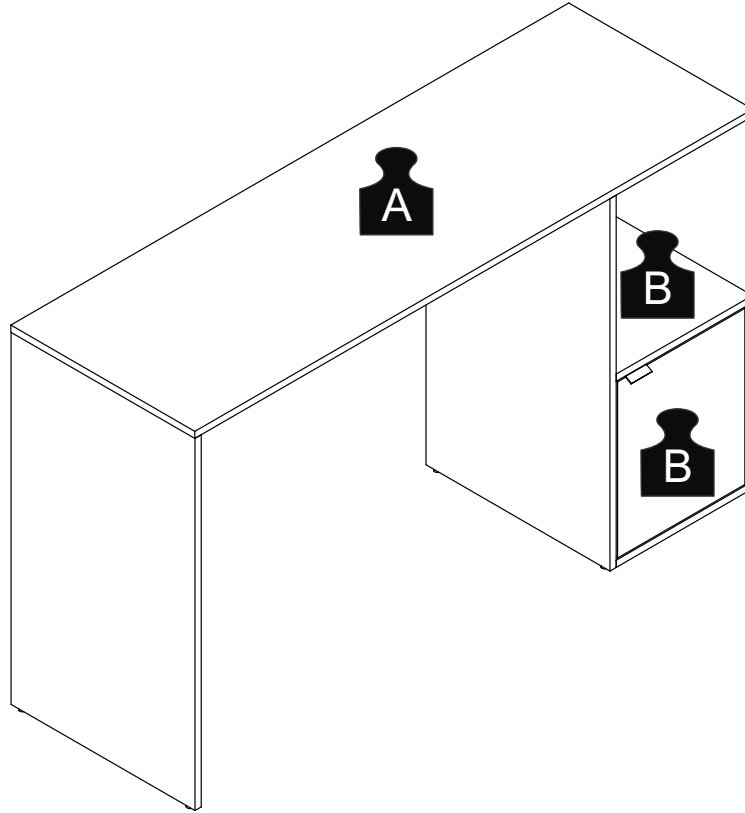

**PASSO 1 / STEP 1 / PASO 1**

Fixe a ferragem EF 000094 nas peças 01, 03, 04 e 06.  
Fix hardware EF 000094 in pieces 01, 03, 04 and 06.  
Fije el herraje EF 000094 en las piezas 01, 03, 04 y 06.

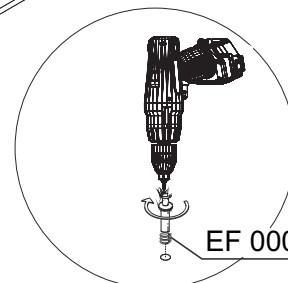
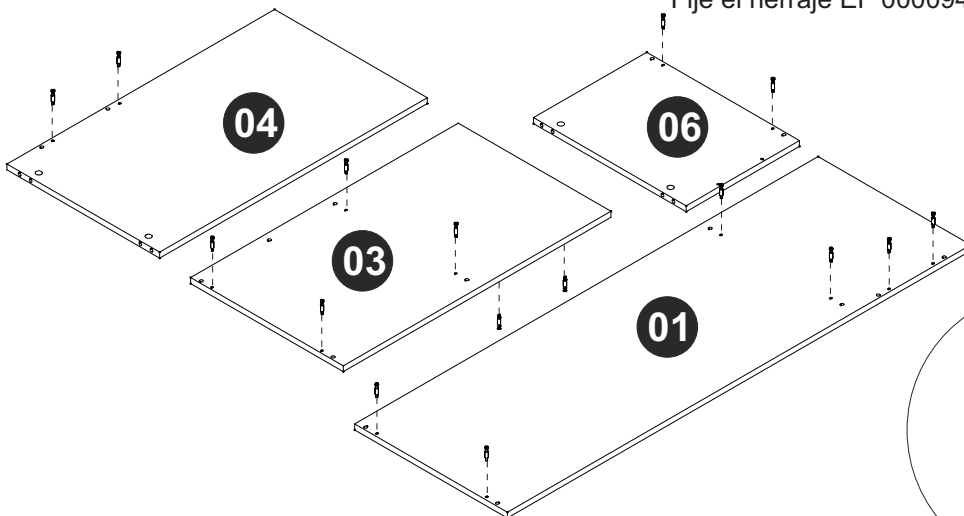

EF 000094





## PASSO 2 / STEP 2 / PASO 2

Insira a ferragem EF 000033 nas peças 02, 03, 04, 05, 06, 07 e 08.  
Insert hardware EF 000033 in pieces 02, 03, 04, 05, 06, 07 and 08.  
Añade el herraje EF 000033 en las piezas 02, 03, 04, 05, 06, 07 y 08.

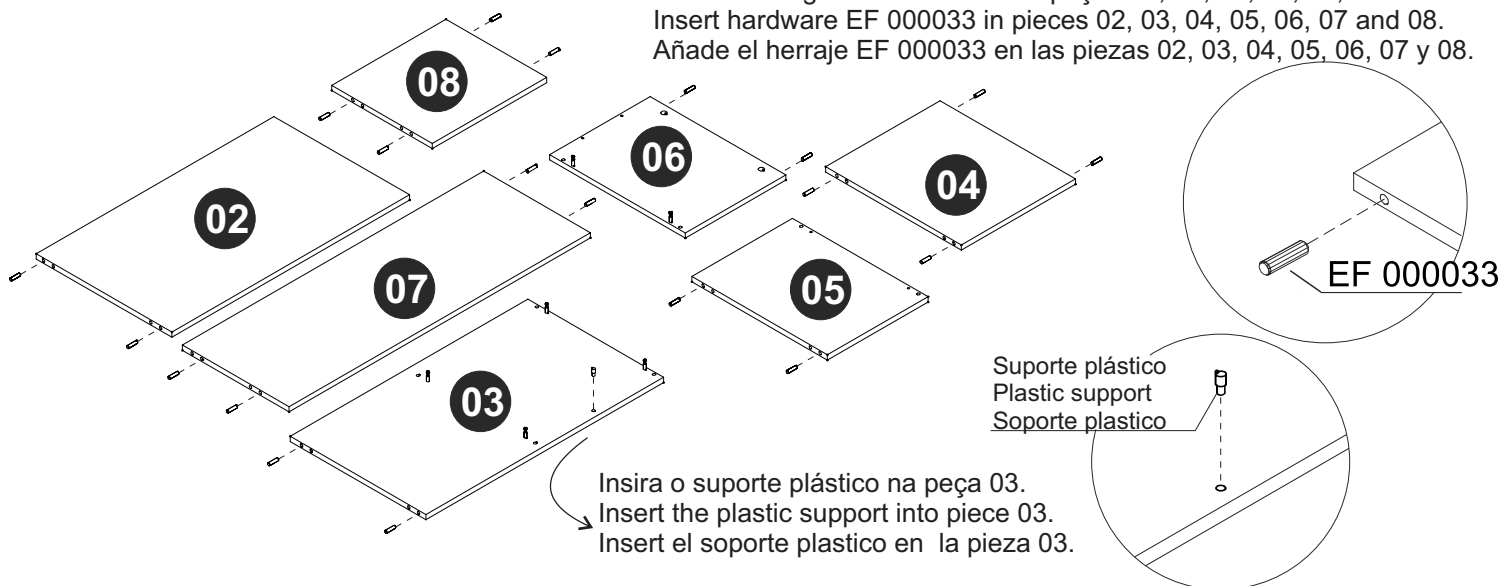

## PASSO 3 / STEP 3 / PASO 3

Fixe a ferragem EF 000025 na peça 04 utilizando a ferragem EF 000106.  
Attach hardware EF 000025 on piece 04 using hardware EF 000106.  
Fije el herraje EF 000025 en la pieza 04 utilizando el herraje EF 000106.

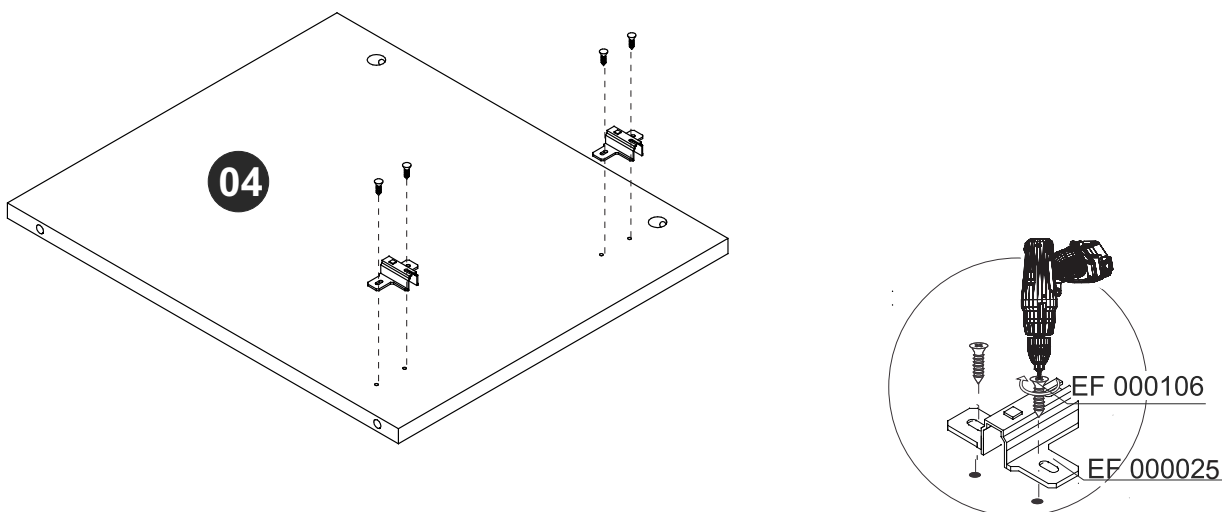

## PASSO 4 / STEP 4 / PASO 4

Fixe a ferragem EF 000043 e o puxador na peça 10 utilizando a ferragem EF 000106.  
Attach hardware EF 000043 and the handle on piece 10 using hardware EF 000106.  
Fije el herraje EF 000043 y la manija en la pieza 10 utilizando el herraje EF 000106.

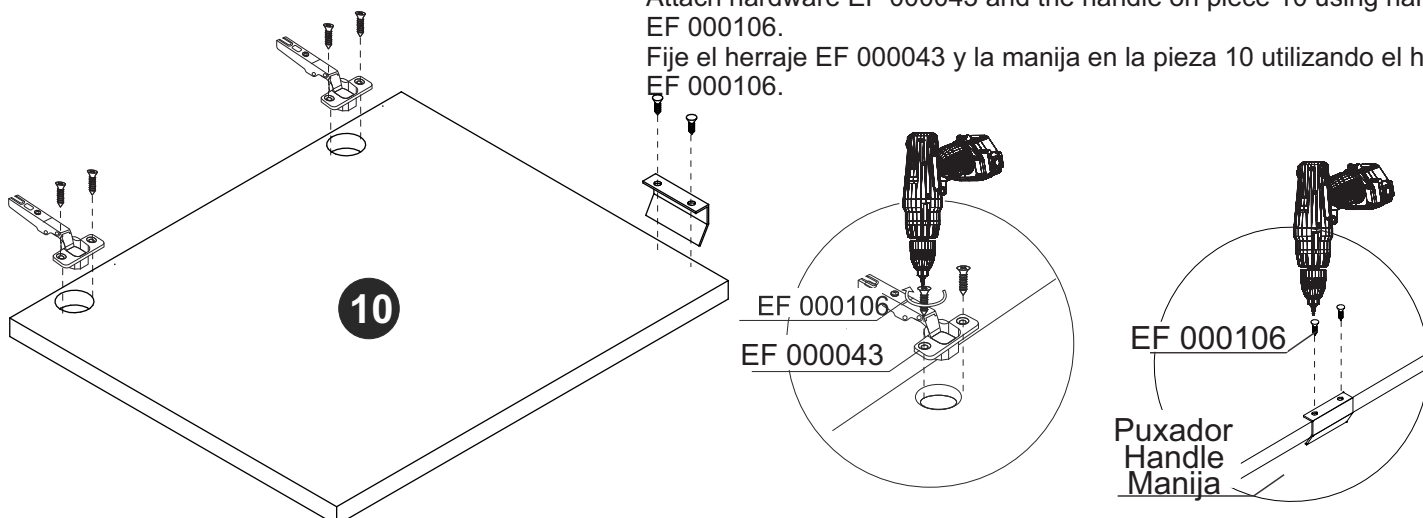

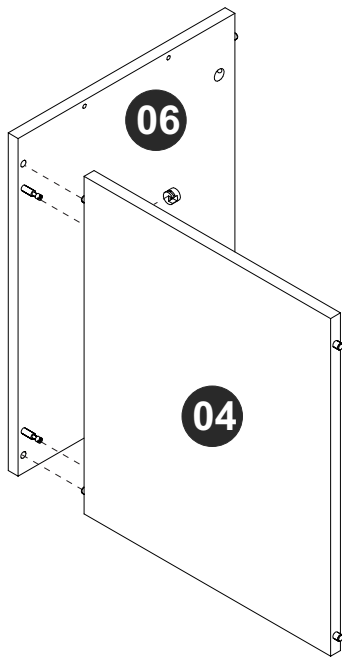

### PASSO 5 / STEP 5 / PASO 5

Conecte as peças 04 e 06, insira a ferragem EF 000216 e gire para apertar.  
 Connect pieces 04 and 06, insert hardware EF 000216 and turn to tighten.  
 Junte las piezas 04 y 06, añade el herraje EF 000216 y gire para apretar.

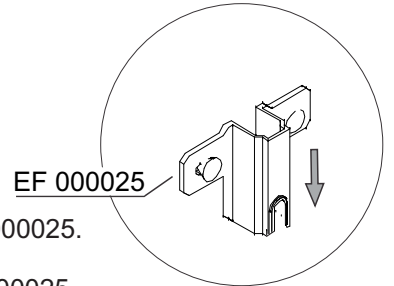
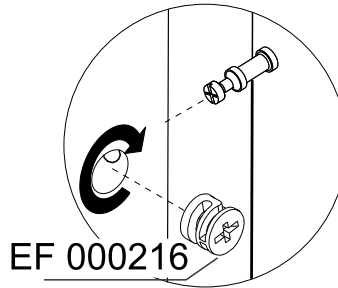

Por favor, observe a posição da ferragem EF 000025.  
 Please, note hardware EF 000025 position.  
 Por favor, observe la posición del herraje EF 000025.

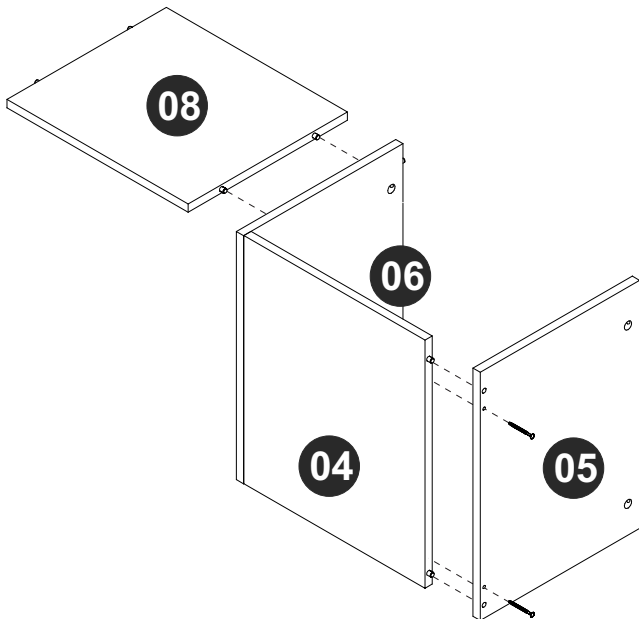

### PASSO 6 / STEP 6 / PASO 6

Conecte as peças 05 e 08 utilizando a ferragem EF 000132.  
 Connect pieces 05 and 08 using hardware EF 000132.  
 Junte las piezas 05 y 08 utilizando el herraje EF 000132.

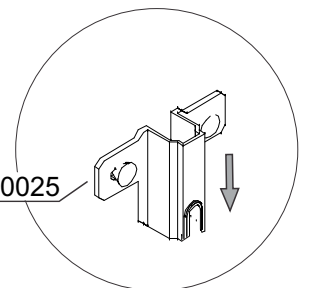
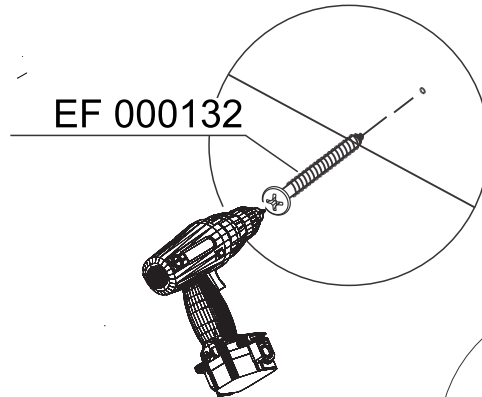

Por favor, observe a posição da ferragem EF 000025.  
 Please, note hardware EF 000025 position.  
 Por favor, observe la posición del herraje EF 000025.

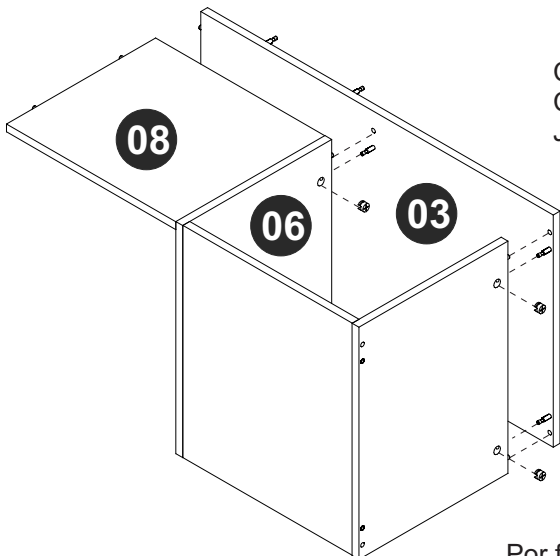

### PASSO 7 / STEP 7 / PASO 7

Conecte a peça 03, insira a ferragem EF 000216 e gire para apertar.  
 Connect piece 03, insert hardware EF 000216 and turn to tighten.  
 Junte la pieza 03, añade el herraje EF 000216 y gire para apretar.

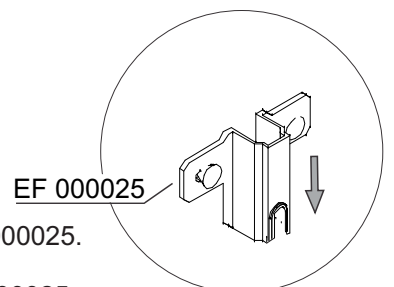
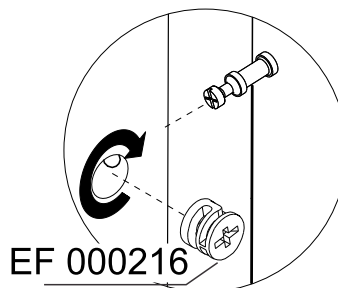

Por favor, observe a posição da ferragem EF 000025.  
 Please, note hardware EF 000025 position.  
 Por favor, observe la posición del herraje EF 000025.

### PASSO 8 / STEP 8 / PASO 8

Conecte as peças 02 e 07, insira a ferragem EF 000216 e gire para apertar.  
Connect pieces 02 and 07, insert hardware EF 000216 and turn to tighten.  
Junte las piezas 02 y 07, añada el herraje EF 000216 y gire para apretar.

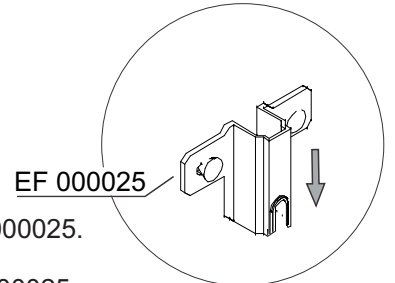
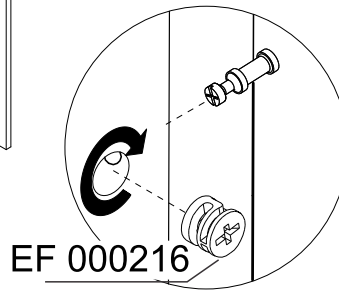
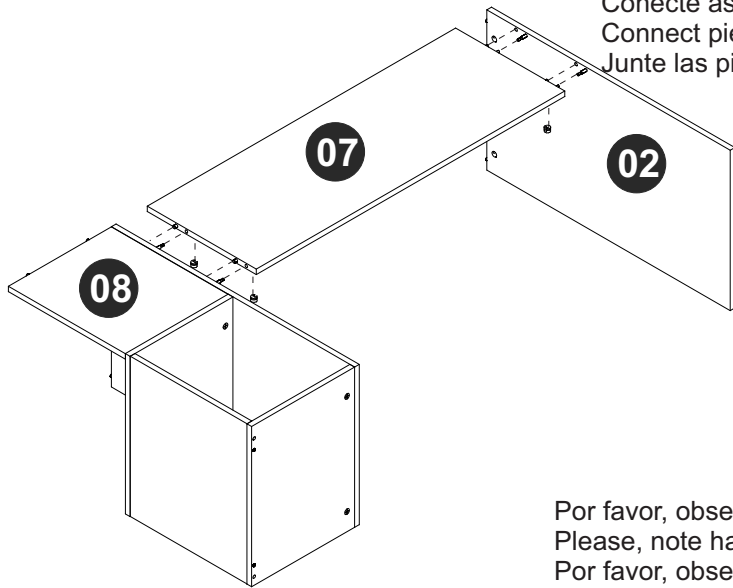

Por favor, observe a posição da ferragem EF 000025.  
Please, note hardware EF 000025 position.  
Por favor, observe la posición del herraje EF 000025.

### PASSO 9 / STEP 9 / PASO 9

Conecte a peça 01, insira a ferragem EF 000216 e gire para apertar.  
Connect piece 01, insert hardware EF 000216 and turn to tighten.  
Junte la pieza 01, añada el herraje EF 000216 y gire para apretar.

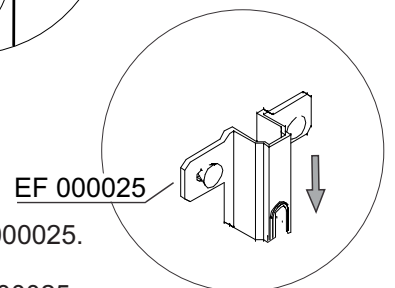
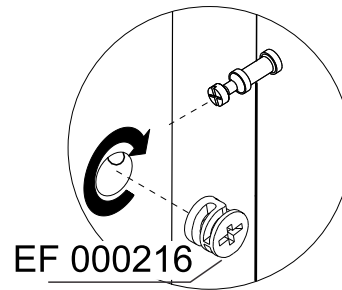
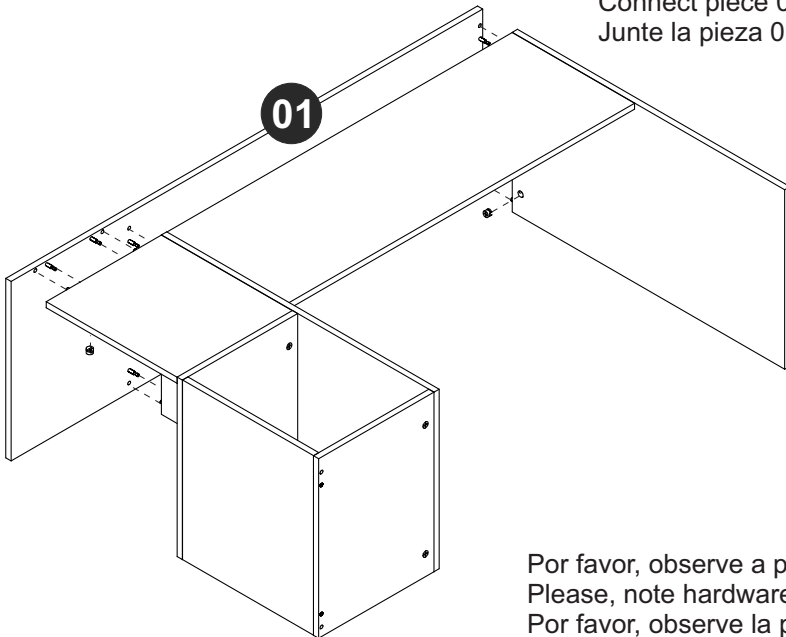

Por favor, observe a posição da ferragem EF 000025.  
Please, note hardware EF 000025 position.  
Por favor, observe la posición del herraje EF 000025.

### PASSO 10 / STEP 10 / PASO 10

Fixe a peça 11 e os pés utilizando a ferragem EF 000168.  
Attach piece 11 and the feet using hardware EF 000168.  
Fije la pieza 11 y los pies utilizando el herraje EF 000168.

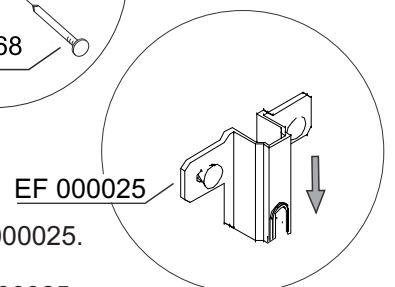
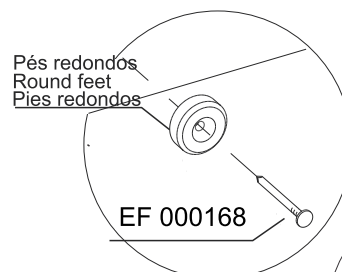
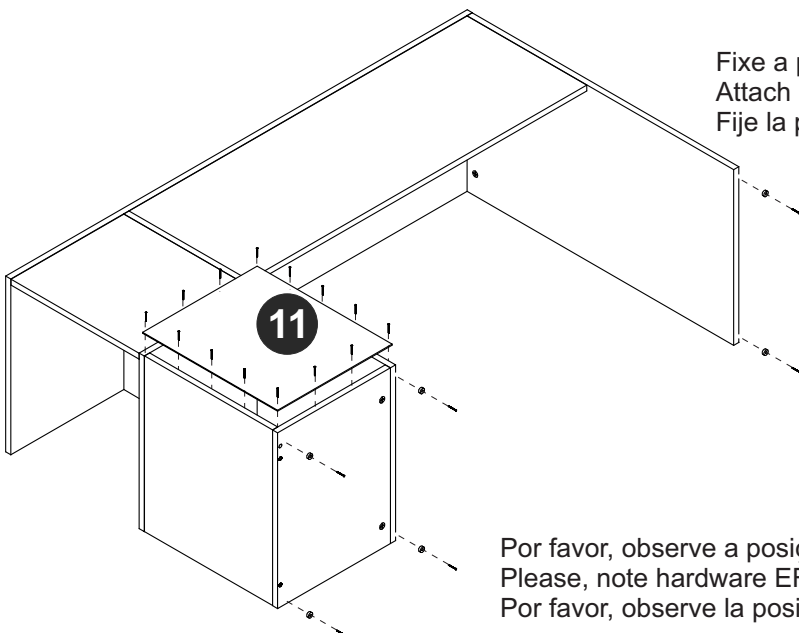

Por favor, observe a posição da ferragem EF 000025.  
Please, note hardware EF 000025 position.  
Por favor, observe la posición del herraje EF 000025.

### PASSO 11 / STEP 11/ PASO 11

Conecte a peça 10 ao móvel montado.  
Connect piece 10 to the assembled furniture.  
Junte la pieza 10 al mueble armado.

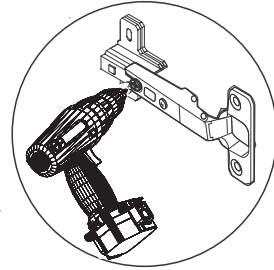
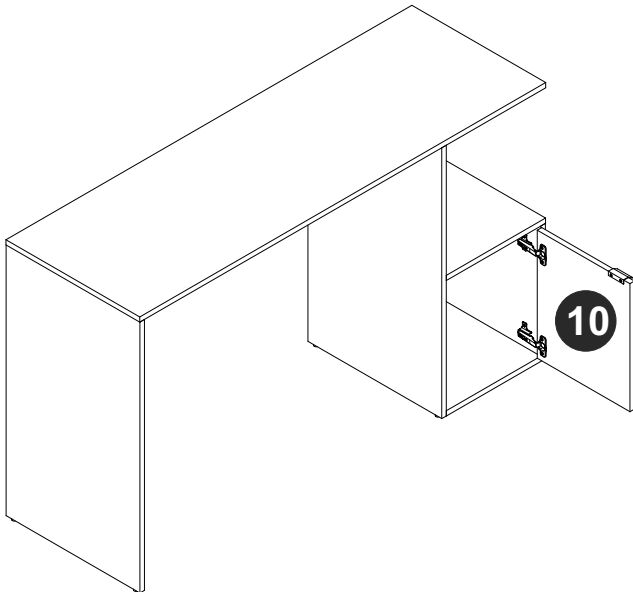

### PASSO 12 / STEP 12 / PASO 12

Use os tapa furos para cobrir os parafusos aparentes.  
Use stickers to cover apparent screws.  
Utilice los tapa huecos para cubrir los tornillos aparentes.

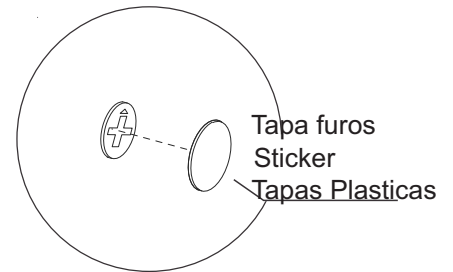
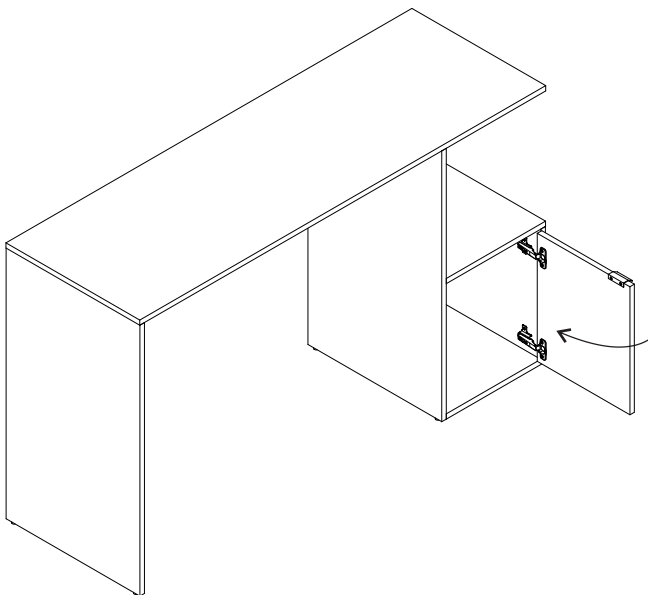

### PASSO 13 / STEP 13 / PASO 13

Use o giz para dar o acabamento final ao produto.  
Use the chalk to give the final finish on the product.  
Utilice la tiza para dar el acabado final al producto.

